

SINGER
72W19

USE SINGER* OILS and LUBRICANTS

They insure freedom from lubricating trouble and give longer life to sewing equipment

The following are the correct lubricants for this machine:

TYPE B — MANUFACTURING MACHINE OIL, HEAVY GRADE

When an oil is desired which will produce a minimum of stain on fabrics, even after a long period of storage, use:

TYPE D — MANUFACTURING MACHINE OIL, HEAVY GRADE

OTHER SINGER LUBRICANTS

TYPE E — THREAD LUBRICANT

For lubricating the needle thread of sewing machines for stitching fabrics or leather where a thread lubricant is required.

TYPE F — MOTOR OIL

For oil lubricated motors and plain bearings in power tables and transmitters.

NOTE: All of the above oils are available in 1 quart, 1 gallon and 5 gallon cans.

GEAR LUBRICANT

This specially prepared grease is recommended for gear lubrication on manufacturing sewing machines.

BALL BEARING LUBRICANT

This pure grease is specially designed for the lubrication of ball bearings and ball thrust bearings of motors and electric transmitters, ball bearing hangers of power tables, etc. **Furnished in 1 lb. and 4 lb. tins.**

1825w

INSTRUCTIONS FOR USING **SINGER*** SEWING MACHINE

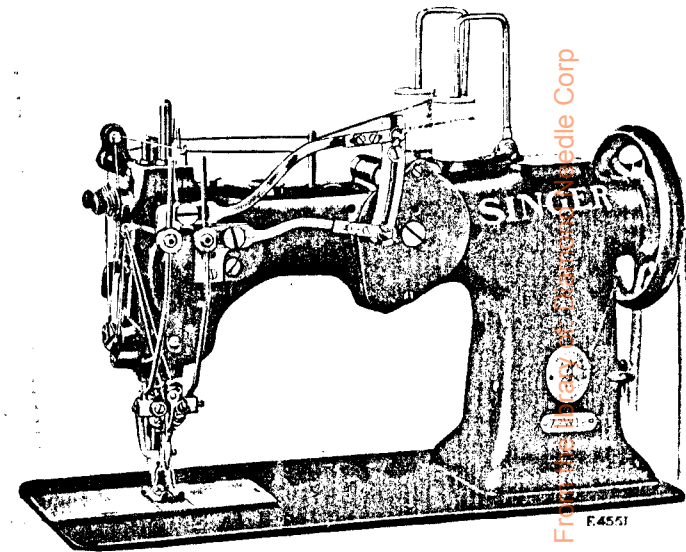

Machine 72w19

No. 72w19

HEMSTITCH

*A TRADE MARK OF

THE SINGER MANUFACTURING COMPANY

TO ALL WHOM IT MAY CONCERN:

The improper placing or renewal of the Trade Mark "SINGER" or any other of the Trade Marks of The Singer Manufacturing Company (all of which are duly Registered Trade Marks) on any machine that has been repaired, rebuilt, reconditioned, or altered in any way whatsoever outside a SINGER factory or an authorized SINGER agency is forbidden.

THE IMPORTANCE OF USING **SINGER*** PARTS AND NEEDLES IN **SINGER** MACHINES

The successful operation of SINGER machines can only be assured if SINGER parts and needles are used. Supplies are available at all SINGER Shops for the Manufacturing Trade, and mail orders will receive prompt attention.

SINGER Needles should be used
in SINGER Machines.
These Needles and their Containers
are marked with the
Company's Trade Mark "SIMANCO.*" 1

Needles in Containers marked
"FOR SINGER MACHINES"
are NOT **SINGER** made needles. 2

Copyright, U. S. A., 1922, 1923, 1925, 1931 and 1933 by
The Singer Manufacturing Company
All Rights Reserved for All Countries

DESCRIPTION

Hemstitch Machine 72w19 is known as of straight-away feed construction and has piercers and double needle actuating device.

The stitch is known as the overedge hemstitch, having each side of the opening overseamed. The piercer divides the cross threads and the stitches collect and hold them in the form of bars or spokes, leaving the clear openings in hemstitch work for which this machine is famous.

Machine 72w19 is fitted for straight-away two needle hemstitch work, having $\frac{1}{8}$ inch openings. It has an independent piercer driving mechanism, and a detachable auxiliary piercer, the function of which is to perforate closely woven, stiff or heavy material in advance of the needles, which work more freely and with less spring in such material than when the auxiliary is not used. While the auxiliary piercer is often used in the production of "imitation drawn work," it is not required for material previously drawn. For ornamental stitching on Shirt Waists, Neckties, Underwear, etc.

From the Library of the Department of Commerce

The number before the hyphen or letter designates the **Class** to which the machine belongs, and the number after, the **Variety** of the machine in its Class.

When supplies for a machine are to be ordered and there is any uncertainty as to the correct numbers of needles or parts, the Class and Variety numbers of the machine, as shown on the number plate, should be given to ensure a correct understanding of the order.

THREAD

Fine thread should always be used. We recommend Nos. 120 to 150 in cotton thread.

SPEED

The maximum speed recommended for Machine No. 72w19 is 1300 stitches per minute. Run the machine somewhat slower than this at first and after the parts have become thoroughly glazed by their action, increase the speed to the maximum stated.

NEEDLES

Needles for Machine No. 72w19 are of Class and Variety 130x3 (usually of sizes 10, 12 and 14).

The needle which is best adapted for the work that the machine is fitted to do is set in the machine at the factory.

The size number of the needle is marked upon its shank.

The Sizes. The size to be used should be determined by the size of the thread which must pass freely through the eye. If rough or uneven thread is used, or if it passes with difficulty through the eye of the needle, the successful use of the machine will be seriously interfered with.

Orders for needles must specify the **quantity** required, the **size**, also the **class** and **variety** numbers, separated by x.

The following are details of an intelligible order:

“100 No. 12—130x3 Needles.”

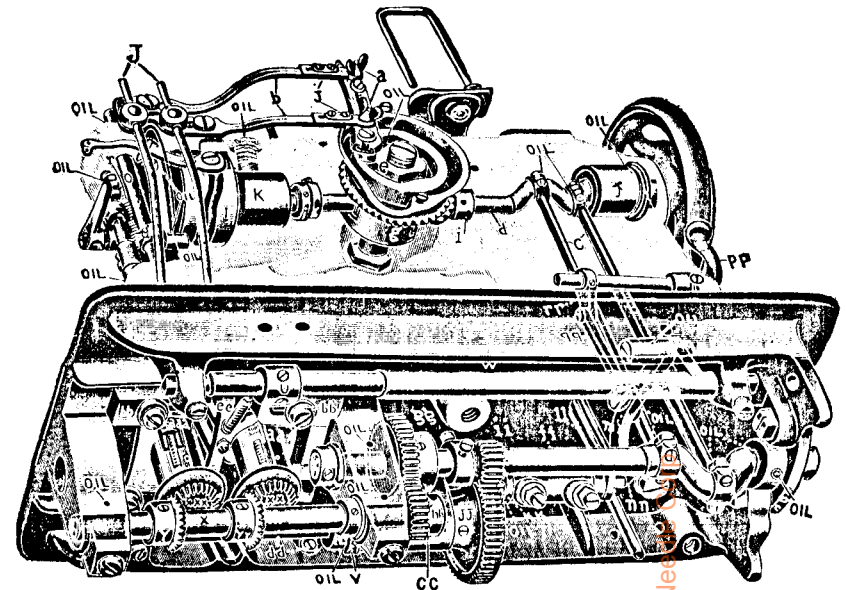

Fig. 2. Machine 72w19. Phantom view, showing places to oil and reference letters.

- | | |
|---|--|
| a—Thumb Nuts, adjustable for width of needle vibration. | aa—Hook Saddle (right). |
| b—Needle Vibrating Cam and Gear Segment Lever Connections. | aaa—Hook Saddle (left). |
| c—Arm Shaft Connections. | bb—Hook Saddle Screw. |
| d—Arm Shaft. | cc—Feed Driving Cam and Gear Shaft Bracket. |
| e—Needle Vibrating Cam and Gear 48 teeth. | dd—Feed Lifting Rock Shaft and Crank, adjustable for height of feed dog. |
| f—Arm Shaft Bushing (back). | ee—Feed Bar. |
| g—Needle Vibrating Cam and Gear Stud. | ff—Hook Driving Shaft. |
| h—Arm Plate (not shown). | gg—Hook Counter Shaft Driving Gear, 44 teeth. |
| i—Needle Vibrating Cam and Gear Driving Gear, 16 teeth. | hh—Hook Counter Shaft Gear, 22 teeth. |
| ik—Piercer Driving Eccentric, adjustable for an earlier or later puncture by the piercer. | ii—Feed Driving Cam and Gear Driving Gear, 18 teeth. |
| j—Needle Vibrating Cam and Gear Segment Lever Connection Links. | jj—Feed Driving Cam and Gear, 54 teeth. |
| k—Arm Shaft Bushing (front). | kk—Feed Driving Segment Lever Crank. |
| l—Take-up Cam. | ll—Feed Driving Segment Lever. |
| o—Needle Bar. | mm—Feed Driving Rock Shaft Connection. |
| p—Needle Bar Connecting Stud, adjustable for height of needle bar. | nn—Feed Driving Segment Lever Clamp. |
| r—Presser Bar Spring. | oo—Hook Driving Shaft Bearing. |
| u—Feed Driving Rock Shaft Crank. | pp—Feed Regulating Handle. |
| v—Feed Lifting Cam. | qq—Feed Regulating Handle Shaft Crank Link. |
| w—Feed Driving Rock Shaft. | rr—Feed Regulating Handle Shaft Crank. |
| x—Hook Counter Shaft. | xx—Hook Bevel Gear Socket (right), 24 teeth. |
| y—Hook Bevel Pinion (left), 24 teeth. | xxx—Hook Bevel Gear Socket (left), 24 teeth. |
| yy—Hook Bevel Pinion (right), 24 teeth. | |

TO OIL THE MACHINE

Use "TYPE B" or "TYPE D" OIL sold only by Singer Sewing Machine Company. For description of oils, see inside of front cover. Oil should be regularly used on any surface of metal which comes in movable contact with another surface.

It is necessary for the easy running of the machine, that all bearings be oiled. The hook especially should have the attention of the operator, as a drop of oil occasionally on the bobbin case base flange prevents excessive friction in the hook race and assists in making the opening between the stop on the bobbin case and that on the throat plate; thus, preventing the upper thread from breaking.

TO SET THE NEEDLES

Turn the balance wheel toward you, to raise the needle bar to its highest position; hold the needle with the flat side of the shank toward the other needle (or center), push it up in the needle holder as far as it can go and tighten the pinch screw.

Care must be taken to set the needles so that they will swing freely, with their points completely housed, into the grooves of the piercer on the inside vibration, to assure clear openings.

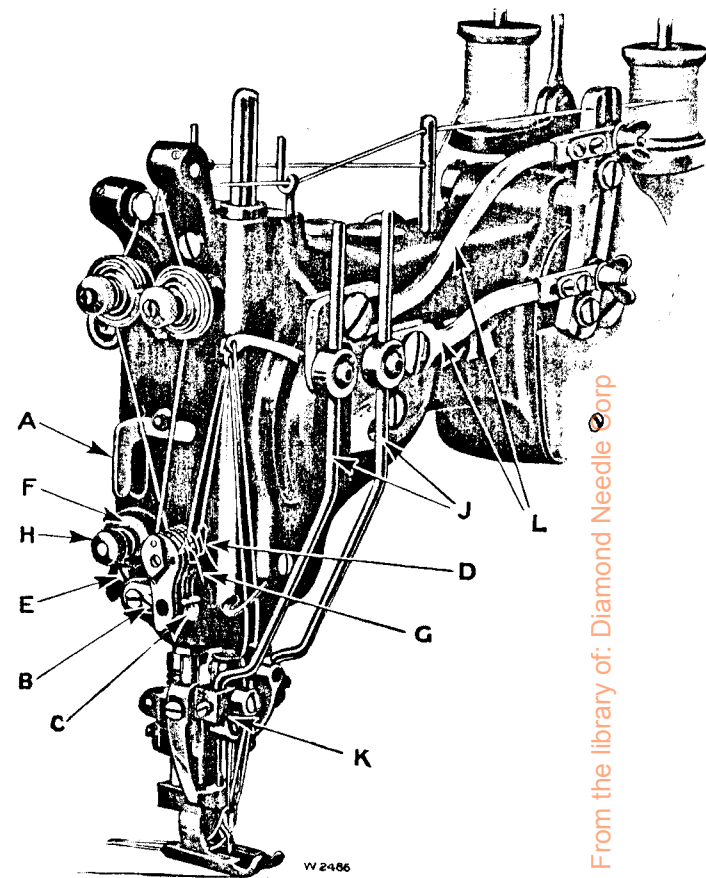

From the library of: Diamond Needle Corp

Fig. 3. Machine No. 72 w 19

TO THREAD THE NEEDLES

Lead the thread from the back spool through the lower hole in the post thread guide, through the eye of the thread guide (back), under the thread retainer guide wire, between the thread retainer and tension discs (back), down under inside thread controller, up through the upper hole in the take-up lever, down through the inside guides to the inside needle, and thread the inside needle from left to right.

Lead the thread from the front spool through the upper hole in the post thread guide, through the eye of the thread guide (front), under the thread retainer guide wire, between the thread retainer and tension discs (front), down under outside thread controller, up through the lower hole in the take-up lever, down through the outside guides to the outside needle, and thread the outside needle from right to left.

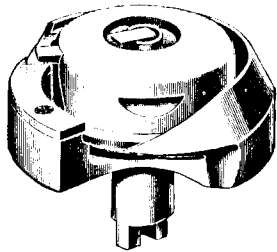

Fig. 4
Hook and Bobbin Case

TO REMOVE THE BOBBIN

Draw back the slides on the bed to uncover the hooks; turn the balance wheel toward you until the notch in the side of the bobbin case cap is accessible; lift out the bobbin case cap by placing your thumb nail in the notch and remove the bobbin.

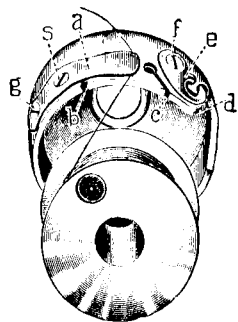

Fig. 5
Bobbin—Bobbin Case Cap

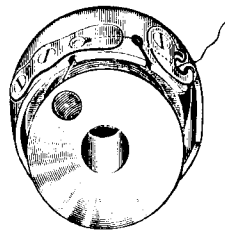

Fig. 6
Bobbin Case Cap
Threaded

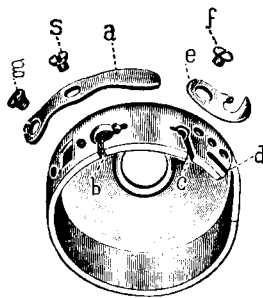

Fig. 7
Bobbin Case Cap Parts

TO THREAD THE BOBBIN CASE CAP

Hold the cap in the left hand, place the bobbin with the thread drawing from the direction shown (see Figs. 5 and 6); then draw the thread under tension spring (a) and through slot (b) back under tension spring (a), through slot (c) and out under thread guide (e) thus threading the cap. After threading, place the cap on the bobbin case base in the machine and push down the latch.

The bobbin case tension is regulated by the screw which passes through the center of the tension spring on the bobbin case.

TO WIND THE BOBBIN

(See Fig. 8)

On machines fitted with loose pulley, turn the thumb screw (C, Fig. 8), at the right of the balance wheel, over toward you to release the balance wheel. It will be necessary to hold the balance wheel while loosening the thumb screw.

Fasten the bobbin winder to the table with its driving pulley in front of the machine belt so that the pulley will drop away from the belt when sufficient thread has been wound upon the bobbin.

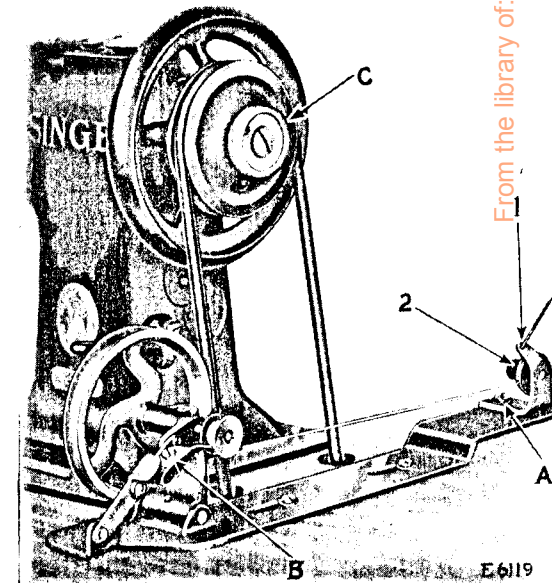

Fig. 8. Winding the Bobbin

Place the bobbin on the bobbin winder spindle and push it on as far as it will go.

Pass the thread down through the thread guide (1) in the tension bracket, around the back and between the tension discs (2). Then wind the end of the thread around the bobbin a few times, push the bobbin winder pulley over against the machine belt and start the machine.

When sufficient thread has been wound upon the bobbin, the bobbin winder will stop automatically.

If the thread does not wind evenly on the bobbin, loosen the screw (A) in the tension bracket and move the bracket to the right or left as may be required, then tighten the screw.

The amount of thread wound on the bobbin is regulated by the screw (B). To wind more thread on the bobbin, turn the screw (B) inwardly. To wind less thread on the bobbin, turn the screw outwardly.

After the bobbin has been wound, turn the thumb screw (C, Fig. 8) over from you to tighten the balance wheel.

KNEE LIFTER

The knee lifter is used for raising the presser foot by knee pressure against the knee plate, leaving both hands free to manipulate the work. If the knee lifter does not raise the presser foot satisfactorily, adjust the rod in the rock lever which connects with the rod in the arm of the machine to lift the presser foot.

STITCH FORMATION AND PIERCER ACTION

How the Straight-away Hemstitch Opening is Made

One double stitch is made on the inside vibration, another on the outside vibration and the third on the inside vibration of the needles. The piercer rises out of the material at every stitch.

First Stitch. On the inside vibration, the piercer, followed by the needles with their points housed in its grooves, enters to its widest part and spreads the material just after the feed dog has dropped below the surface of the throat plate; as the needles rise they spread a little for the hooks to catch the thread loops.

Second Stitch. On the outside vibration the needles descend spread apart, each needle entering the material outside of and the piercer within the opening, to make the stitches which draw and hold the bar (or spoke) stitches up to the material in imitation of hand work.

Third Stitch. On the inside vibration, the piercer, followed by the needles with their points housed in its grooves, descends again into the opening for the third stitch. After the piercer and needles rise sufficiently clear of the material the feed dog rises and moves the material forward for the needles to work the first stitch in the next opening, binding the intervening threads of the material into a bar (or spoke). Each set of three stitches for each opening is formed in the same manner.

The piercer usually set in the machine at the factory is No. 213826. Piercer No. 213825 is finer, for extra fine work, silks, etc.

The auxiliary piercer is No. 234739.

PIERCERS AND AUXILIARY PIERCERS USED IN MACHINE 72 w 19 ALSO DIAGRAMS SHOWING SHAPES

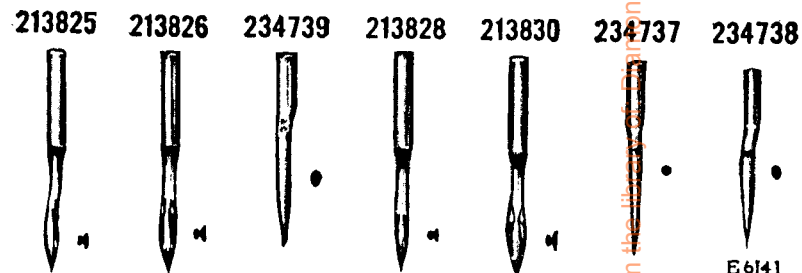

Fig. 9

The above diagrams show exact sizes and shapes of punctures.

TO COMMENCE SEWING

With the left hand take hold of the needle threads, leaving them slack between the hand and the needles, turn the balance wheel toward you until the needles move down and up again to their highest position, thus catching the under threads, draw up the needle threads and the under threads with them through the slots in the throat plate and lay the four threads back underneath the presser foot; then place the material beneath the needles, lower the presser foot upon it, turn the balance wheel toward you, and commence to sew.

THE TENSIONS

Both upper tensions are regulated by the thumb nuts in front of the tension discs.

Both upper and bobbin case tensions should be as light as possible consistent with a perfect stitch.

To release the tension without disturbing the presser foot or work, push lever (A, see Fig. 3) from you.

Caution. Do not try to adjust the tensions when the presser foot is up. For convenience in removing the work, the tension of the upper threads is released whenever the presser foot is raised by the lifter, but is not released by the rising of the presser foot as goods or seams pass under it.

LENGTH OF STITCH

The length of stitch should be governed by the kind of material to be hemstitched; a stitch that is too short will not leave a sufficient number of threads between the openings in fine material to insure against their breaking.

Correctly formed stitches require careful adjustment of the needle vibration in relation to the length of stitch and width of bight; much however depends upon the texture of the fabric to be hemstitched, and necessary adjustments should be made at each change of fabric.

TO TURN A SQUARE CORNER

After the piercer has entered the material for what is to be the last opening in a straight line, and before the needles are down, turn the material at right angles to the last line of openings and proceed to stitch as before. There will be no extra hole punctured at the corner by the auxiliary piercer.

TO REMOVE THE WORK

Have the take-up lever at its highest point; raise the presser foot, draw the work back to the left and cut the threads close to the goods.

INSTRUCTIONS

FOR

ADJUSTERS AND MACHINISTS

INSTRUCTIONS
FOR
ADJUSTERS AND MACHINISTS

THREAD CONTROLLER

See Fig. 3

The function of the thread controller spring is to hold back the slack of the upper threads until the eyes of the needles reach the goods in their descent.

For a longer action of the double thread controllers, loosen screw (B) and set stop (C) lower. For less action of the thread controllers, reverse the operation.

To strengthen the action of the inside thread controller (D), loosen screw (E) and turn nut (F) to the right and tighten the screw.

To strengthen the action of the outside thread controller (G), loosen the set screw in thumb nut (H) and turn thumb nut (H) to the right, then tighten the set screw. For lighter action reverse the operations.

TO CHANGE THE LENGTH OF STITCH

The clamp screw (nn, see Fig. 2) is tightened so that an operator cannot change the number of stitches to the inch for which the machine is set; but if a change of stitch is desired, loosen screw (nn) and tighten it after moving handle (pp) for the desired length of stitch. If handle (pp) moves too easily, tighten the screw at the left of and close to the handle.

TO ADJUST THE FEED DOG

The feed dog should rise and show a full tooth above the throat plate as the eyes of the needles come up level with the plate after forming the third stitch in the opening. The feed dog should not begin to move forward for the next opening until the needle points are clear of the goods.

The feed dog must be kept level so as to afford the best condition for handling the material. To level the feed dog use adjusting screw at (ee, see Fig. 2) and secure by check nut.

TO RAISE OR LOWER THE FEED DOG

See Fig. 2

Clean the lint and dirt from it; tip back the machine and turn the balance wheel toward you until the feed is at its highest position; loosen the screw of crank (dd) and move it up or down until the feed is at the desired height and tighten the screw in crank (dd).

The feed dog does not require adjusting except for some unusual kind of work or if badly worn.

FEED ADJUSTMENTS

See Fig. 2

The feed adjustments which follow are seldom required, but, if an adjustment becomes necessary, take care that the position of the other parts is not changed.

To cause the feed to start earlier after the feed dog is up and the needles are clear of the goods, carefully loosen the screws in feed driving gear (ii) and slightly turn the top of the feed driving gear toward you, which sets cam and gear (jj) forward, be careful not to make too great a change, then tighten the screws firmly. If the feed does not start as early as required, repeat the operation. To make the feed start later move the top of feed driving gear (ii) slightly from you. Any change made in the time of cam and gear (jj) may necessitate a change of the position of feed lifting cam (V).

For an earlier drop of the feed dog, move or set the top of cam (V) from you, and for a later drop of the feed dog, move or set it toward you.

NEEDLES—ADJUSTMENT OF BIGHT OR VIBRATION

See Figs. 2 and 3

The spreading and drawing in or vibratory action of the needles is caused by needle vibrating cam and gear (e) driven by driving gear (i), connected by lever connections (L) and levers (J) to the needle holders (K).

On the outside vibration, the lever connections (L) draw levers (J) toward each other and spread them on the inside vibration, by their connection with needle holders (K).

On the descending inside vibration of the needles, their eyes should be on a level with the material before they commence to move outward toward the hooks, which will bring the strain of the expanding needles upon their shanks when they have reached the lowest portion of the stroke of the needle bar.

To Change the Vibration of Either Needle. For a narrow vibration adjust thumb nut (a) toward the center and for a wider vibration adjust it from the center of the vibrator lever.

Should the points of the needles as they descend upon the inside vibration appear outside of the grooves of the piercer, a very fine adjustment may be made by turning needle vibrating lever (J, see Figs. 17 and 18, screws Q) slightly to the left or right to swing needle holder (K) in the direction required; thus keeping the needles properly housed during their descent.

As the needle lever pitmans are independently mounted, they must be separately adjusted.

Lengthening the lower pitman makes the inside needle vibrate farther over the edge of the material, to the right, and shortening the upper pitman makes the outside needle vibrate farther over the edge of the material, to the left.

To obtain the best results and a uniform action of the needles, great care must be taken to set thumb nut (a, see Fig. 2) of each pitman an equal distance from the center of the needle vibrator lever. Should the pitman require lengthening or shortening to obtain a correct position of the needle, loosen screws (j) and move the pitman to the desired position, then retighten the screws. If these adjustments do not suffice, the time of cam and gear (e), on the arm shaft may be changed by loosening the set screws in pinion (i) and turning it slightly for an earlier or later vibration of the needles.

Either needle can be set closer to or farther from the other (see Figs. 16 and 17) by loosening nuts (OO) and adjusting hinge screws (R).

Great care must be taken when making any change of time, not to make the change too great or carelessly. See that all of the screws are tightened firmly before starting the machine.

NEEDLE BAR

To Set the Needle Bar. Two lines $\frac{3}{32}$ inch apart are marked across the bar about $1\frac{3}{4}$ inch from its lower end; when the needle bar is at its lowest position set it so that the highest mark is even with the underside of the needle bar bushing.

To Set a Needle Bar Which Has no Mark. Set the needle bar so that when it rises $\frac{3}{32}$ inch from its lowest position, the point of the hook will be at the center of the needle and about $\frac{1}{16}$ inch above the eye; by looking across the top of the bobbin case down to the eye, the full length of the eye should be seen below and close up to the point of the hook.

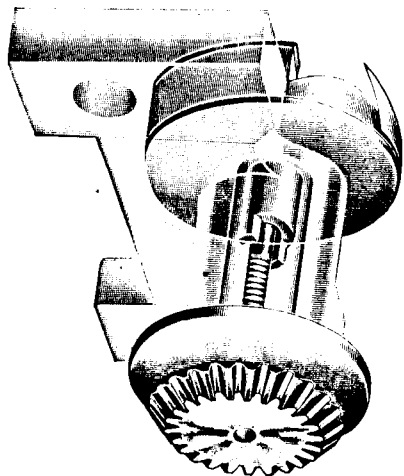

Fig. 10

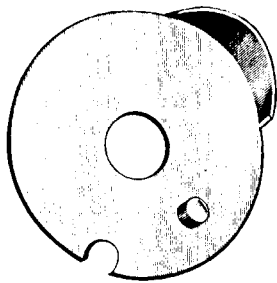

Fig. 11
Hook Washer

Transparent view of saddle, with hook, gear socket, and screw (200555), passing down through the hook into the gear socket, binding them together.

HOOK (SEWING) ADJUSTMENTS

To See if the Hooks are in Correct Time. Remove the slides and throat plate and turn the balance wheel toward you until the needle bar has passed its lowest position and risen so that the lower mark on it is even with the underside of the needle bar bushing. If in correct time, the point of each hook will be at the center of each needle and $\frac{1}{16}$ inch above the eye; if not, loosen the screws in the bevel gear on the shaft under the hook and turn the gear forward or backward slightly until the hook is in time as instructed above, then retighten the screws.

Be sure that the needle guard on the hook washer (see Fig. 11) does not deflect the needle. If the hook is too far from or too near the needle, loosen hook saddle screws (bb), see Fig. 2) just enough to permit the saddle to be driven with light blows to the position desired, then retighten the screws.

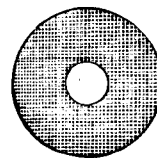

Fig. 12
Bobbin Case Washer (Cloth)

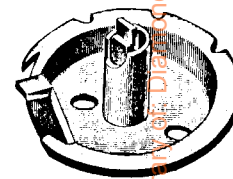

Fig. 14
Bobbin Case Base

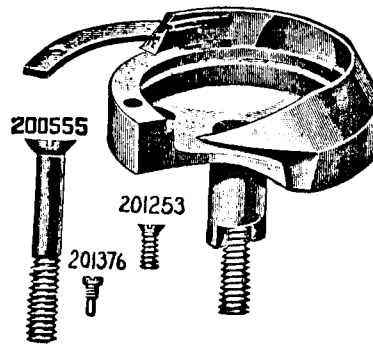

Fig. 13
Hook Gib, Hook Gib Screw, Hook Gib Hinge Screw and Hook Socket Screw

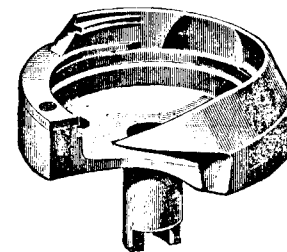

Fig. 15
Hook (Sewing) with Gib and Screws

From the Library of the Department of the Interior, Bureau of Reclamation

SEWING HOOKS

See Figs. 13 to 15

To Remove Either Hook from the Machine. Remove the gib screw at the heel of the hook and move the gib aside to allow the base of the bobbin case to be taken out, after which remove the screw, from the center of the hook, shown in the cut. Tapping the hook lightly from below on the bottom of its rim will force it from its socket. Do not pry it out, as prying may bend the shank of the hook. In replacing the hook be sure that the prongs of the shank properly enter the slot at the bottom of the socket, otherwise the hook will be out of time.

To Remove Arm Shaft (d, see Fig. 2). Through the oil hole near the needle bar loosen the set screw and remove the check and position screws from the take-up cam; loosen piercer bar driving cam screws, loosen the position screw at the back of the arm which holds bushing (f), detach connections (c) from the upper cranks, insert a light flexible rod through the large hole in the arm over the cranks, drive out bushing (f) and draw out the shaft.

To Remove Front Bushing (k). Loosen its position screw at the back of the arm and after removing the needle bar, take-up cam, etc., insert a rod through shaft bushing hole (back) and drive out the front bushing.

When Replacing the Bushing see that the groove in the bushing is in line for the position screw to enter, then drive the bushing as far as it will go and tighten the screw. When setting the take-up cam be sure to replace its position screw in the hole nearest to the presser bar, when the screw holes are uppermost, and turn it down firmly into the shaft, and replace the check screw over it. The end play of the upper shaft is taken up by means of the screw in the end of the shaft at the balance wheel.

In Attaching the Balance Wheel to the shaft, the screw farthest from the operator should enter the groove in the shaft, when both screws are uppermost, otherwise the wheel will be out of balance and cause the machine to shake.

AUXILIARY PIERCER T

To Set the Auxiliary Piercer. Loosen screw (P, see Fig. 16) and set bracket (U) forward or backward as required. As the

function of the auxiliary piercer is to open the material in advance of the piercer, it must be set in correct relation to the length of stitch, so that the advance perforations made by it may be correctly entered by the piercer and needles.

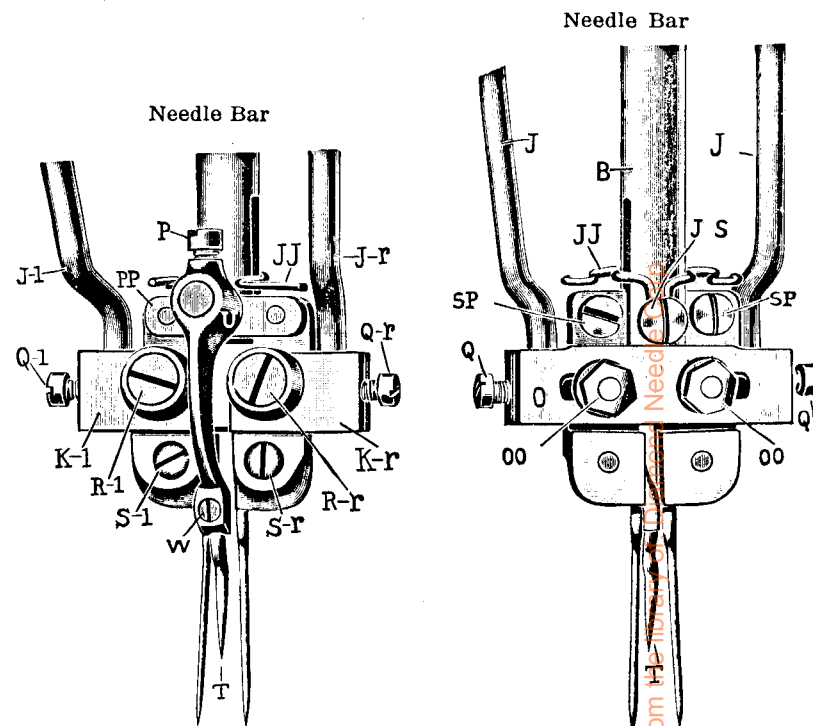

Fig. 16
Front view

Fig. 17
Back view

For Machines of Class 72w. Showing the needle bar with the hinged needle holders, auxiliary piercer, and needle vibrating levers, front and back views

- | | |
|---|---|
| B—Needle Bar. | Q—Needle Vibrating Lever Screws. |
| S—Needle Set Screws. | JJ—Thread Guide (double). |
| K—Needle Holders. | T—Auxiliary Piercer. |
| O—Needle Holder Bracket. | U—Auxiliary Piercer Holder. |
| JS—Needle Holder Bracket Screw. | P—Auxiliary Piercer Holder Screw. |
| R—Needle Holder Hinge Screws, adjustable, to change the permanent location of the needle holders toward or from each other. | PP—Auxiliary Piercer Holder Bracket |
| OO—Needle Holder Hinge Screw Nuts. | SP—Auxiliary Piercer Holder Bracket Screws. |
| J—Needle Vibrating Levers. For a fine adjustment of needle vibration, turn slightly to the left or right as required. | W—Auxiliary Piercer Set Screw. |

PIERCER TT

The piercer bar is adjustable for a higher or lower position of the piercer.

The piercer should be set to rise to the correct height, clear of the material, and the feed should complete its forward movement before the piercer enters the goods, otherwise clear openings cannot be made.

The piercer should be timed so that it will enter and spread the material to its widest opening as the needles descend with their points housed in the grooves of the piercer.

To change the time of the piercer in relation to the needles, move eccentric (ik see Fig. 2) on the arm shaft for an earlier or later movement of the piercer.

Should it be necessary to remove piercer (TT, see Fig. 18) it is preferable to detach holder (UU) at screw (ABS).

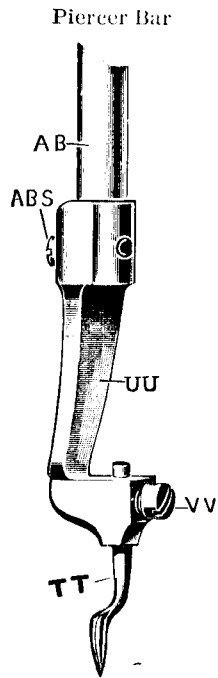

Fig. 18

AB—Piercer Bar
 ABS—Piercer Holder Screw
 TT—Piercer
 UU—Piercer Holder
 VV—Piercer Screw

ADJUSTABLE HEMSTITCH PRESSER FOOT

Usually there is but one thickness of goods under the outside (shire side) foot plate, while there are several thicknesses under the inside (hem side) foot plate.

To set the outside lower than the inside foot plate, loosen the pinch screw and turn outward the upright screw, then tighten the pinch screw. Adjust the pressure on the foot plates so as to maintain an even pressure although the thickness of the material to be hemstitched may vary or be changed.

To increase the pressure on the material under the outside foot plate, loosen the collar and push it down to compress the spring.

For more pressure on the inside foot plate, turn down the thumb screw on top of the arm, and for less pressure, turn it up.

Flat work requires an even pressure on the foot plates.

The lowest screw holds the presser foot on the presser bar. Careful adjustments will produce the desired effect.

INSTRUCTIONS FOR ATTACHING SINGER PICOT EDGE CUTTING ATTACHMENT 234734

This device will be furnished, on order, at an additional charge to the machine.

1. Remove the regular Presser Foot and Presser Bar Guide from the machine and fasten the Presser Bar Guide and Support 234723, Fig. 19, and Presser Foot 247643, Fig. 19, in position on the machine as shown in Fig. 19.

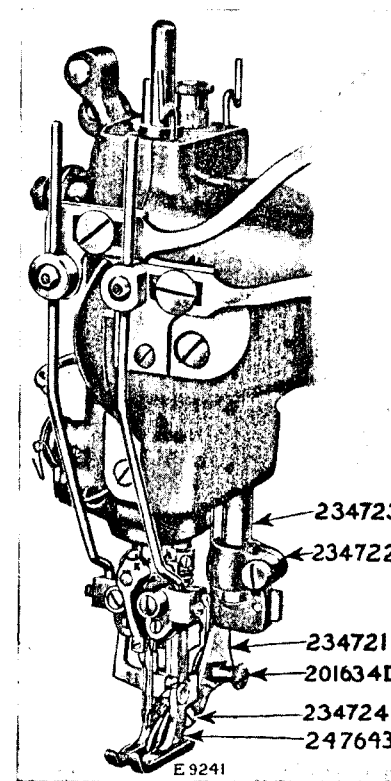

Fig. 19

2. Adjust the machine, test it, set to the length of stitch desired and be sure that it is in proper sewing condition.
3. Place Picot Edge Cutting Blade Arm Bracket 234722, Fig. 19, in position on Presser Bar Guide 234723, Fig. 19.

4. Turn the Balance Wheel until the Piercer is at its highest point and the Feed Dog is below the Throat Plate, and have the Presser Foot rest on the Throat Plate.

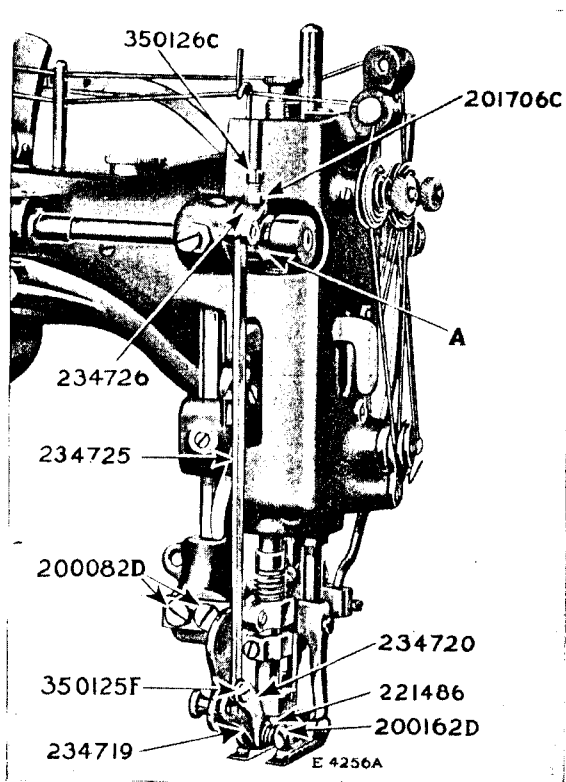

Fig. 20

5. Place the Attachment (with Thumb Nut 201634D, Fig. 19, at the back end of slot) in position by inserting the Knives in between the Presser Foot Shoes, and fasten the Attachment on the Arm Bracket 234722, Fig. 19, with the two screws 200082D, Fig. 20.
6. Loosen the Pinch Screw in the Arm Bracket and raise the Attachment on the Presser Bar Guide until the centre of the Knife Fulcrum Stud 234724, Fig. 19, is $\frac{7}{16}$ " above the top of the Throat Plate. Place a scale or straight edge across Attachment Arm 234721, Fig. 19, from front to back, and line up parallel with the presser foot, the cutting edges of the knives to be in line with the centre of the Piercer, then tighten the Pinch Screw.

7. Remove the Set Screw in the Rock Shaft Collar (A, Fig. 20).
8. Place the Operating Lever 234726, Fig. 20, in position on the Rock Shaft Collar (A), using Screw 350126c, Fig. 20, in place of Set Screw and Check Nut 201706c, Fig. 20, to hold the Lever and Rock Shaft Collar in position.
9. Raise the Operating Lever until the point of the Upper Knife Blade lightly touches the Throat Plate, holding the lever with the left hand, turn the balance wheel with the right hand until the Piercer reaches its lowest position.
10. Fasten the Operating Lever with the Screw and Nut, using care to have the point of the upper Knife Blade 234720, Fig. 20, just above the Throat Plate.

(CAUTION: If the Piercer touches the Knife Blades before reaching the lowest position, it will be necessary to raise it sufficiently to clear both knife blades; this will not interfere with the quality of hemstitching.)

(CAUTION: If the knife is set too low, the point of the knife will be broken by striking the Throat Plate.)

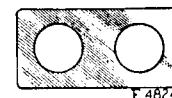

Fig. 21

11. Loosen the Thumb Nut 201634D, Fig. 19, and pull it forward until the point of the lower Knife Blade 234719, Fig. 20, rests on the Throat Plate, then tighten the Thumb Nut. The point of the knife should be just back of the needle hole.

The position of the knives back of the needles is very important as they should cut the second bar only in order to make small curves and turn square corners.

The knives should not cut into the first bar back of the needles as this bar is required to hold the fabric in forming the hemstitch. If the knives cut into the first bar, which may occur when using a long stitch, there are two shims 234735 (Fig. 21) which have been provided to insert between 234721 and 234722 (Fig. 19) to position the knives further back so that they will cut the second bar only.

(CAUTION: Be sure that the point of the knife touches the top of the Throat Plate, otherwise part of the fabric may pass between the Knife and Throat Plate and some be cut and some of it torn, resulting in ragged and unsatisfactory work.)

12. Make a careful inspection to see that all parts are in position as described, test screws and nuts and see that they are properly tightened. If found correct and you have the Attachment in proper position, you are now ready to operate.

(CAUTION: More care will have to be exercised by the operator when using a hemstitch machine fitted with a Picot Edge Cutting Attachment than on hemstitching alone.)

Before using this Attachment on a garment, the operator should try it out on scrap material, operating the machine at slow speed until thoroughly familiar with it.

Special care should be exercised in respect to the bobbins, so that they are not allowed to run out. In view of the fact that the hemstitch feeds only every third stitch, the machine can be easily stopped when a thread breaks, without cutting more than one bar, and this is easily repaired by going over the unstitched place, using underneath a small piece of the same material.

13. When it is desired to do straight hemstitching with the Attachment in place, loosen Thumb Nut 201634D, Fig. 19, and push it to the back end of the slot, then tighten it. This will raise the lower knife so as to permit the fabric to pass under it.

TO REMOVE THE KNIFE BLADES FOR SHARPENING

Remove the Cap Screw 200162D, Fig. 20, together with Spring 221486, Fig. 20, and Hinge Screw 350125F, Fig. 20, push back the knife blade Hinge Stud 234724, Fig. 19; both knife blades can then be easily removed or replaced.

INSTRUCTIONS FOR SHARPENING KNIVES OF PICOT EDGE CUTTING ATTACHMENT 234734

When using Picot Edge Cutting Attachment 234734, the best results are obtained when the knives are sharpened on Knife Grinder 234746.

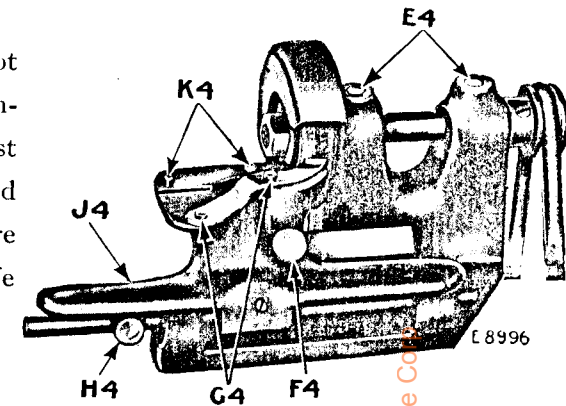

Fig. 22. Knife Grinder 234746

The grinder should be set so that the top of the emery wheel turns over toward the operator at about 3000 revolutions per minute.

To Sharpen Lower Knife 234719, place it in position on the two rear pins (K4, Fig. 22). Loosen the lock screw (H4, Fig. 22) and move the knife carrier (J4, Fig. 22) until the left edge of the blade is in line with the left edge of the grinding wheel. Then move the lock screw (H4) to the right until it bears against the casting and securely tighten the lock screw (H4). (The setting of the lock screw (H4) is important, as it prevents the body of the lower knife from being ground. After the lock screw has been once properly set, it is not necessary to change its position when sharpening either knife.) Turn the adjusting screw (F4, Fig. 22) in or out until the knife bears lightly against the grinding wheel. Start the grinder and with the forefinger of the left hand pressing lightly on the knife between the pins, sharpen the full length of the cutting edge of the knife by moving the knife carrier (J4) from side to side. The least possible amount ground off is usually sufficient.

To Sharpen Upper Knife 234720, place it in position on the two pins (G4, Fig. 22). Set the adjusting screw (F4) and sharpen the blade as instructed above for the lower knife.

Caution: The knives should barely graze the emery wheel. If the knives are held with too much pressure against the emery wheel, the temper of the knives may be drawn until they are too soft for use.

Lubrication: Oil should be regularly applied to the two ball oilers (E4, Fig. 22).

INSTRUCTIONS FOR MAKING SQUARE CORNERS AND CURVES

A square corner is easily made in the following manner:

1. When the Piercer is descending after the feeding operation takes place, the two needles are brought close to the Piercer.
2. Allow the Piercer to enter the fabric.
3. Raise the Presser Foot and using the Piercer as a pivot, turn the fabric to a right angle.
4. Turn the material which lies back of the Presser Foot over away from Presser Foot and Knives.
5. Lower Presser Foot and with forefingers on material at each side of Presser Foot even with the needles and thumbs in front of and slightly to side of Presser Foot, spread the material out flat.
6. Start the machine slowly for a few stitches, aiding the feeding of material with the hands just enough to bring the corner out back of the Presser Foot so that the fabric on both sides of the Knives can be grasped by forefinger and thumb of one hand to gently pull the material in aiding the feed, as is customary in hemstitching.

If the foregoing instructions are followed carefully, clean cut corners will be made without cutting or breaking the threads, or injuring the fabric.

To make curves, hold the fabric flat with thumbs and forefingers of both hands, turning the fabric carefully with the hands during the feeding operation, taking care to not turn it too far at any one time. The Knives cut the second bar back of the needles, which permits making quite small curves. With a little practice, the operator will find this easy to accomplish.

**SINGER Needles should be used
in SINGER Machines
These Needles and their Containers
are marked with the
Company's Trade Mark "SIMANCO.*" 1**

**Needles in Containers marked
"FOR SINGER MACHINES"
are NOT SINGER made needles. 2**